

FOR MESSRS : _____

DATE : Dec. 06th, 2025

CUSTOMER'S ACCEPTANCE SPECIFICATIONS

TX20D207VM0AAA



Contents

No.	ITEM	SHEET No.	PAGE
1	COVER	7B64PS 2701-TX20D207VM0AAA-3	1-1/1
2	RECORD OF REVISION	7B64PS 2702-TX20D207VM0AAA-3	2-1/1
3	GENERAL DATA	7B64PS 2703-TX20D207VM0AAA-3	3-1/1
4	ABSOLUTE MAXIMUM RATINGS	7B64PS 2704-TX20D207VM0AAA-3	4-1/1
5	ELECTRICAL CHARACTERISTICS	7B64PS 2705-TX20D207VM0AAA-3	5-1/2~2/2
6	OPTICAL CHARACTERISTICS	7B64PS 2706-TX20D207VM0AAA-3	6-1/2~2/2
7	BLOCK DIAGRAM	7B64PS 2707-TX20D207VM0AAA-3	7-1/1
8	RELIABILITY TESTS	7B64PS 2708-TX20D207VM0AAA-3	8-1/1
9	LCD INTERFACE	7B64PS 2709-TX20D207VM0AAA-3	9-1/7~7/7
10	OUTLINE DIMENSIONS	7B64PS 2710-TX20D207VM0AAA-3	10-1/2~2/2
11	APPEARANCE STANDARD	7B64PS 2711-TX20D207VM0AAA-3	11-1/3~3/3
12	PRECAUTIONS	7B64PS 2712-TX20D207VM0AAA-3	12-1/2~2/2
13	DESIGNATION OF LOT MARK	7B64PS 2713-TX20D207VM0AAA-3	13-1/1

ACCEPTED BY: _____

PROPOSED BY: Max Lee

2. RECORD OF REVISION

DATE	SHEET No.	SUMMARY
Feb.01,'23	7B64PS 2701 – TX20D207VM0AAA-2 Page 1-1/1	Company logo changed :  →  Kaohsiung Opto-Electronics Inc. Japan Display Inc.
	7B64PS 2713 – TX20D207VM0AAA-2 Page 13-1/1	Company name changed: From “KAOHSIUNG OPTO-ELECTRONICS INC.” to “JDI Taiwan Inc. Kaohsiung Branch”
	All page	
Dec.06,'25	7B64PS 2709 – TX20D207VM0AAA-3 Page 9-2/7	9.3 TIMING CHART Revised TIMING CHART

3. GENERAL DATA

3.1 DISPLAY FEATURES

This module is a 8.0" WXGA of 16:9 format LTPS TFT. The pixel format is vertical stripe and sub pixels are arranged as R(red), G(green), B(blue) sequentially. This display is RoHS compliant, and COG (chip on glass) technology and LED backlight are applied on this display.

Part Name	TX20D207VM0AAA
Module Dimensions	189.5 (W) mm x 119.4 (H) mm x 11.6 (D) mm (Typ.)
LCD Active Area	173.952 (W)mm x 104.3712(H)mm
Pixel Pitch	0.1359 (W) mm x 0.1359 (H) mm
Resolution	1280x 3 (RGB) (W) x 768 (H) dots
Color Pixel Arrangement	RGB Vertical Stripe
LCD Type	Transmissive Type, Normally Black
Display Type	Active Matrix
Number of Colors	16.7M Colors (8-bit RGB)
Backlight	Light Emitting Diode (LED)
Weight	254g(typ)
Interface	LVDS ; 20pins
Power Supply Voltage	3.3V for LCD ; 12V for Backlight
Viewing Direction	Super Wide Version

4. ABSOLUTE MAXIMUM RATINGS

Item	Symbol	Min.	Max.	Unit	Remarks
Supply Voltage	V _{DD}	-0.3	4.6	V	-
Input Voltage of Logic	V _I	-0.3	3.6	V	Note 1
Operating Temperature	Top	-40	85	°C	Note 2
Storage Temperature	T _{st}	-40	90	°C	Note 2
Backlight Input Voltage	V _{LED}	-	15	V	-

Note 1: The rating is defined for the signal voltage of the interface such as CLK, BLEN, SD, BL_PWM and pixel data pairs.

Note 2: The maximum rating is defined as above based on the panel surface temperature, which might be different from ambient temperature after assembling the panel into the application. Moreover, some temperature-related phenomenon as below needed to be noticed:

- Background color, contrast and response time would be different in temperatures other than 25°C.
- Operating under high temperature will shorten LED lifetime.

5. ELECTRICAL CHARACTERISTICS

5.1 LCD CHARACTERISTICS

$T_a = 25\text{ }^\circ\text{C}$, $V_{SS} = 0\text{V}$

Item	Symbol	Condition	Min.	Typ.	Max.	Unit	Remarks
Power Supply Voltage	V_{DD}	-	3.0	3.3	3.6	V	-
Differential Input Voltage for LVDS Receiver Threshold	V_I	V_{IH}	-	-	+100	mV	Note 1
		V_{IL}	-100	-	-		
Power Supply Current	I_{DD}	$V_{DD}-V_{SS} = 3.3\text{V}$	80	100	143	mA	Note 2,3
Frame Frequency	f_{Frame}	-	58.2	60	61.8	Hz	Note 4
CLK Frequency	f_{CLK}	-	65	67	69	MHz	

Note 1: VCM 1.2V is common mode voltage of LVDS transmitter and receiver. The input terminal of LVDS transmitter is terminated with 100Ω .

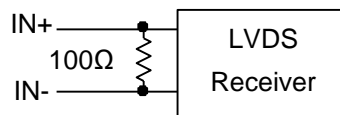

Note 2: An all white check pattern is used when measuring I_{DD} . f_{Frame} is set to 60Hz.

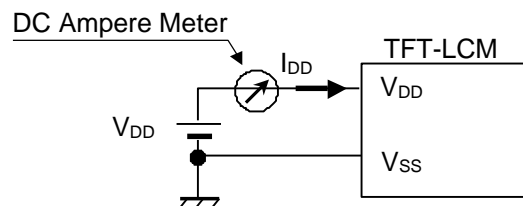

Note 3: 1.5A fuse is applied in the module for I_{DD} . For display activation and protection purpose, power supply is recommended larger than 3.75A to start the display and break fuse once any short circuit occurred.

Note 4: For LVDS transmitter input.

5.2 BACKLIGHT CHARACTERISTICS

$T_a = 25\text{ }^\circ\text{C}$

Item	Symbol	Condition	Min.	Typ.	Max.	Unit	Remarks
LED Input Voltage	V_{LED}	Backlight Unit	10.8	12	13.2	V	Note 1
LED Forward Current (Dim Control)	I_{LED}	100% duty	-	570	630	mA	Note 2
		0% duty	-	6.0	-		
Backlight Enable	BLEN	Backlight Unit	1.5	-	5.5	V	
LED Lifetime	-	$I_{LED}=570\text{mA}$	-	70K	-	hrs	Note 3
PWM signal	BL_PWM	Backlight Unit	1.5	-	5.5	V	

Note 1: Fig. 5.1 shows the LED backlight circuit.

Note 2: Dimming function can be obtained by applying PWM signal from the display interface CN7. The recommended PWM signal is 1K ~ 10KHz with 3.3 V amplitude.

Note 3: The estimated lifetime is specified as the time to reduce 100% brightness by applying 570mA at $25\text{ }^\circ\text{C}$.

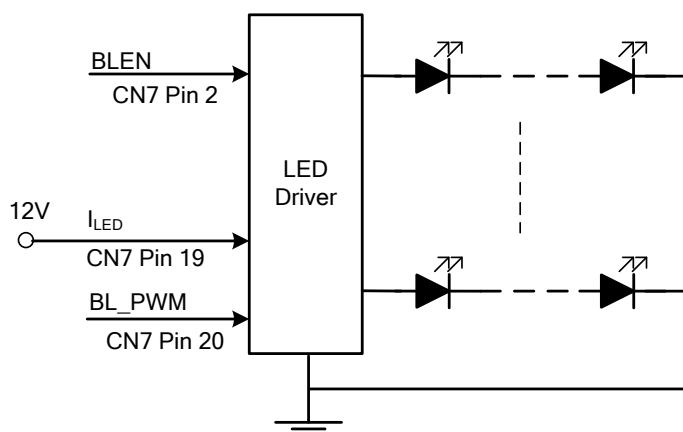

Fig 5.1

6. OPTICAL CHARACTERISTICS

The optical characteristics are measured based on the conditions as below:

- Supplying the signals and voltages defined in the section of electrical characteristics.
- The ambient temperature is 25 °C .
- In the dark room less than 100 lx, the equipment has been set for the measurements as shown in Fig 6.1.

$$T_a = 25\text{ }^\circ\text{C}, f_{Frame} = 60\text{ Hz}, V_{DD} = 3.3\text{V}$$

Item	Symbol	Condition	Min.	Typ.	Max.	Unit	Remarks	
Brightness of White	-	$I_{LED} = 570\text{mA}$ $\phi = 0^\circ, \theta = 0^\circ$	960	1200	-	cd/m^2	Note 1	
Brightness Uniformity	-		70	-	-	%	Note 2	
Contrast Ratio	CR		900	1400	-	-	Note 3	
Response Time	$T_r + T_f$	$\phi = 0^\circ, \theta = 0^\circ$	-	19	25	ms	Note 4	
NTSC Ratio	-	$\phi = 0^\circ, \theta = 0^\circ$	-	70	-	%	-	
Viewing Angle	θ_x	$\phi = 0^\circ, CR \geq 10$	75	85	-	Degree	Note 5	
	$\theta_{x'}$	$\phi = 180^\circ, CR \geq 10$	75	85	-			
	θ_y	$\phi = 90^\circ, CR \geq 10$	75	85	-			
	$\theta_{y'}$	$\phi = 270^\circ, CR \geq 10$	75	85	-			
Color Chromaticity	Red	X	$\phi = 0^\circ, \theta = 0^\circ$	0.61	0.66	0.71	-	Note 6
		Y		0.27	0.32	0.37		
	Green	X		0.26	0.31	0.36		
		Y		0.58	0.63	0.68		
	Blue	X		0.09	0.14	0.19		
		Y		0.00	0.04	0.09		
	White	X		0.25	0.30	0.35		
		Y		0.26	0.31	0.36		

Note 1: The brightness is measured from the center point of the panel, P5 in Fig. 6.2, for the typical value.

Note 2: The brightness uniformity is calculated by the equation as below:

$$\text{Brightness uniformity} = \frac{\text{Min. Brightness}}{\text{Max. Brightness}} \times 100\%$$

which is based on the brightness values of the 9 points measured by BM-5 as shown in Fig. 6.2.

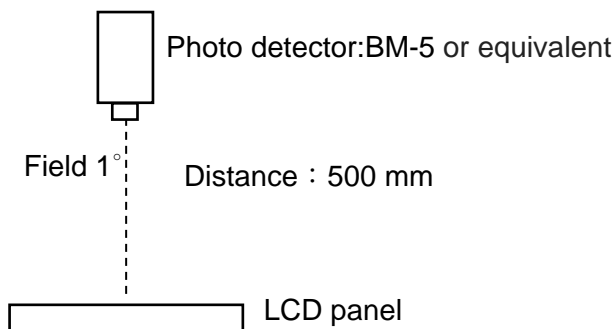

Fig. 6.1

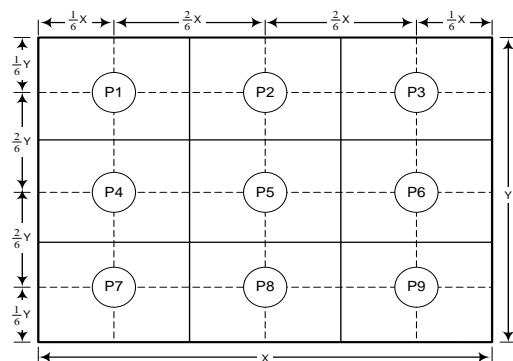

Fig. 6.2

Note 3: The Contrast ratio is measured from the center point of the panel, P5, and defined as the following equation:

$$CR = \frac{\text{Brightness of White}}{\text{Brightness of Black}}$$

Note 4: The definition of response time is shown in Fig. 6.3. The rising time is the period from 10% brightness to 90% brightness when the data is from black to white. Oppositely, Falling time is the period from 90% brightness falling to 10% brightness.

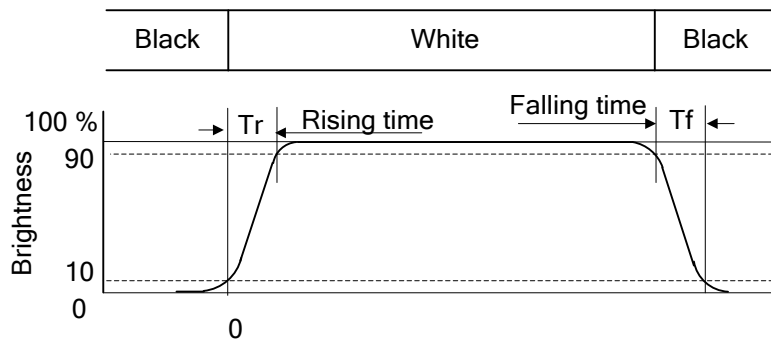

Fig. 6.3

Note 5: The definition of viewing angle is shown in Fig. 6.4. Angle ϕ is used to represent viewing directions, for instance, $\phi = 270^\circ$ means 6 o'clock, and $\phi = 0^\circ$ means 3 o'clock. Moreover, angle θ is used to represent viewing angles from axis Z toward plane XY.

The display is super wide viewing angle version, so that the best optical performance can be obtained from every viewing direction.

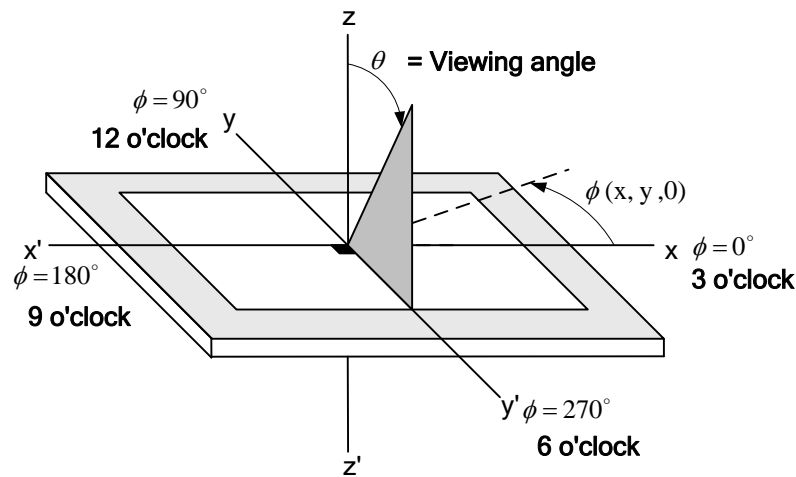
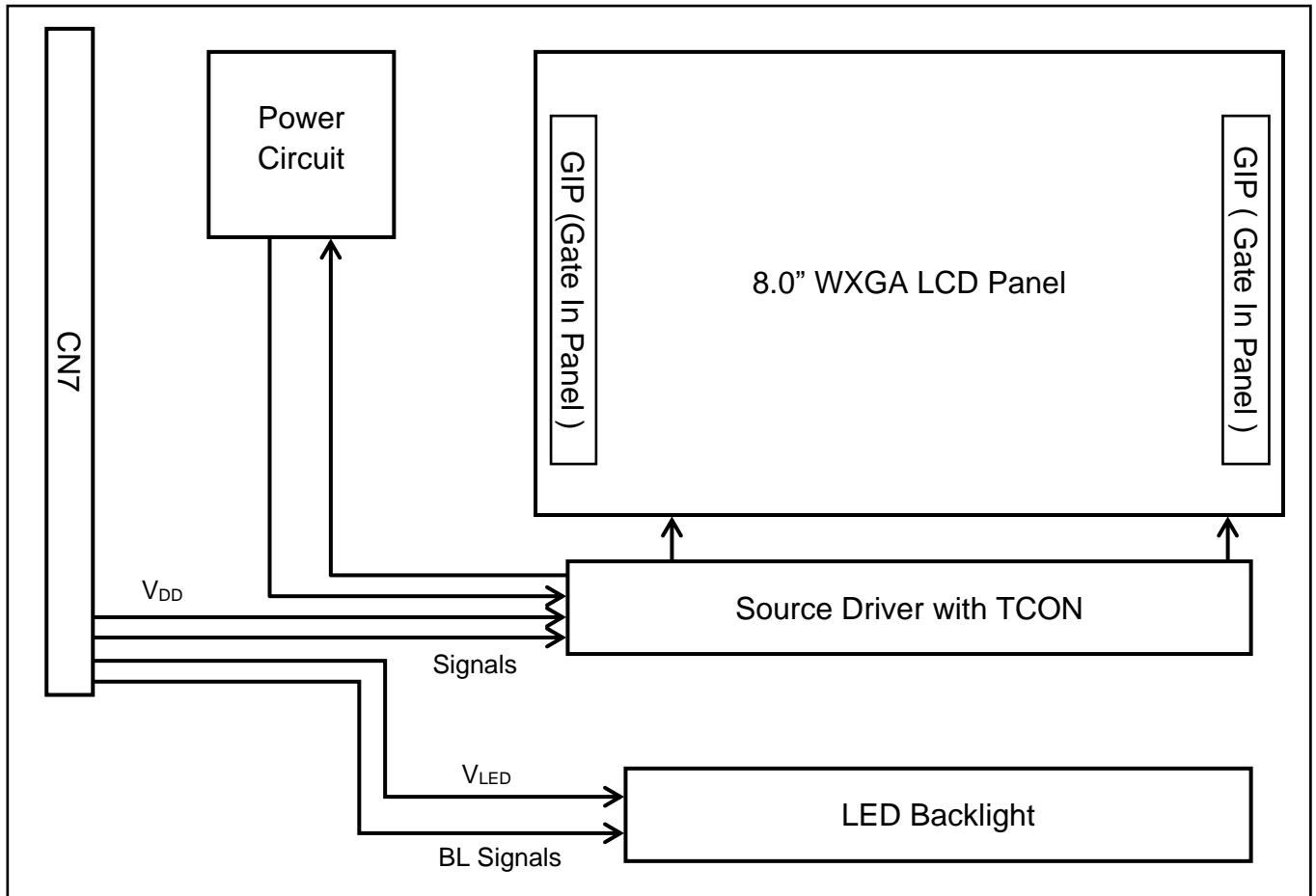

Fig. 6.4

Note 6: The color chromaticity is measured from the center point of the panel, P5, as shown in Fig. 6.2.

7. BLOCK DIAGRAM



Note :

- 1) Signals are SD, CLK and pixel data pairs
- 2) BL signals are BLEN and BL_PWM.

8. RELIABILITY TESTS

Test Item	Condition	
High Temperature	1) Operating 2) 85°C	500 hrs
Low Temperature	1) Operating 2) -40°C	500 hrs
High Temperature	1) Storage 2) 90°C	500 hrs
Low Temperature	1) Storage 2) -40°C	500 hrs
Heat Cycle	1) Operating 2) -40°C ~85°C 3) 3hrs~1hr~3hrs	500 hrs
Thermal Shock	1) Non-Operating 2) -40°C ↔ 85°C 3) 0.5 hr ↔ 0.5 hr	500 hrs
High Temperature & Humidity	1) Operating 2) 65°C & 85%RH 3) Without condensation	500 hrs (Note 3)
Vibration	1) Non-Operating 2) 10~200 Hz 3) 5G 4) X, Y, and Z directions	1 hr for each direction
Mechanical Shock	1) Non-Operating 2) 10 ms 3) 80G 4) ±X, ±Y and ±Z directions	Once for each direction
ESD	1) Operating 2) Tip: 150 pF, 330 Ω 3) Air discharge for glass: ± 12KV 4) Contact discharge for metal frame: ± 15KV	1) Glass: 9 points 2) Metal frame: 8 points (Note4)

Note 1: Display functionalities are inspected under the conditions defined in the specification after the reliability tests.

Note 2: The display is not guaranteed for use in corrosive gas environments.

Note 3: Under the condition of high temperature & humidity, if the temperature is higher than 60°C, the humidity needs to be reduced as Fig. 8.1 shown.

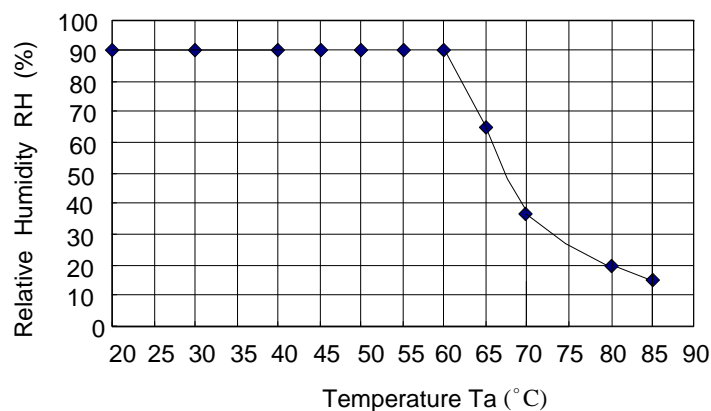

Fig. 8.1

Note 4: All pins of LCD interface (CN1) have been tested by ± 100V contact discharge of ESD under non-operating condition.

9. LCD INTERFACE

9.1 INTERFACE PIN CONNECTIONS

The display interface connector (CN3) is FI-SEB20P-HF13E made by JAE and pin assignment is as below:

Pin No.	Symbol	Signal	Pin No.	Symbol	Signal
1	V _{DD}	Power Supply for Logic	11	IN2-	B2~B5, DE
2	BLEN	Backlight Enable	12	IN2+	
3	V _{SS}	GND	13	V _{SS}	GND
4	SD	Scan Direction Control High :Normal, Low :Reverse	14	CLK IN-	Pixel Clock
5	IN0-	R0~R5, G0	15	CLK IN+	
6	IN0+		16	V _{SS}	GND
7	V _{SS}	GND	17	IN3-	R6, R7, G6, G7, B6, B7
8	IN1-	G1~G5, B0~B1	18	IN3+	
9	IN1+		19	V _{LED}	Backlight power input
10	V _{SS}	GND	20	BL_PWM	Backlight Dimming

Note 1: IN n- and IN n+ (n=0, 1, 2, 3), CLK IN- and CLK IN+ should be wired by twist-pairs.

9.2 LVDS INTERFACE

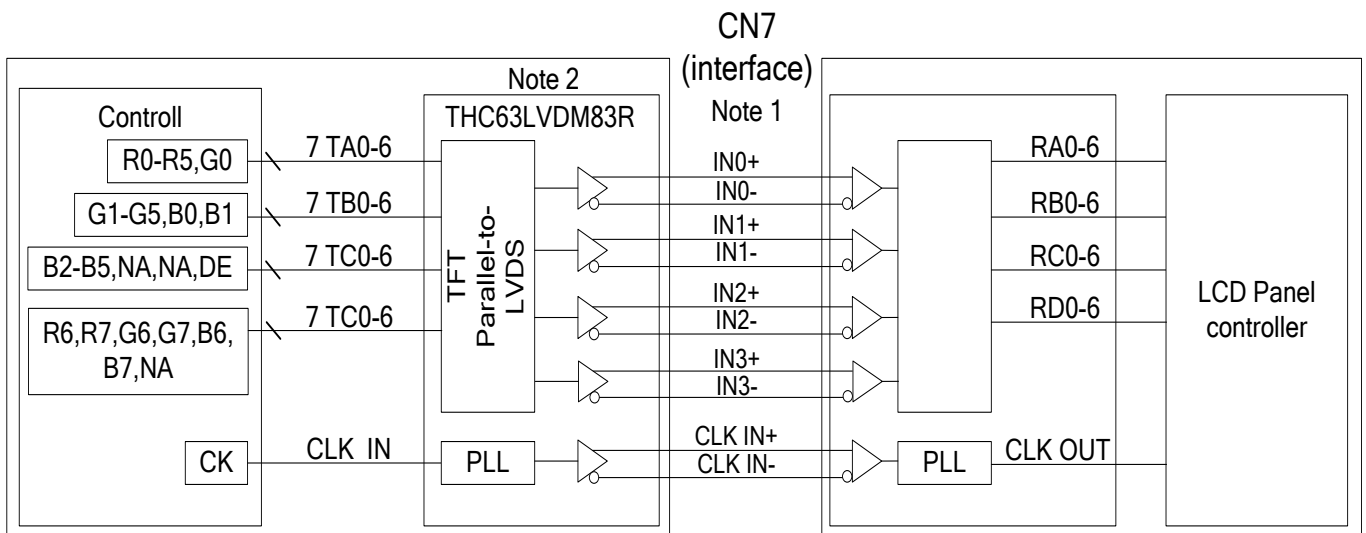

Note 1: LVDS cable impedance should be 100 ohms per signal line when each 2-lines (+, -) is used in differential mode.

Note 2: The recommended transmitter, THC63LVDM83R, is made by Thine or equivalent, which is not contained in the module.

9.3 TIMING CHART

Horizontal timing

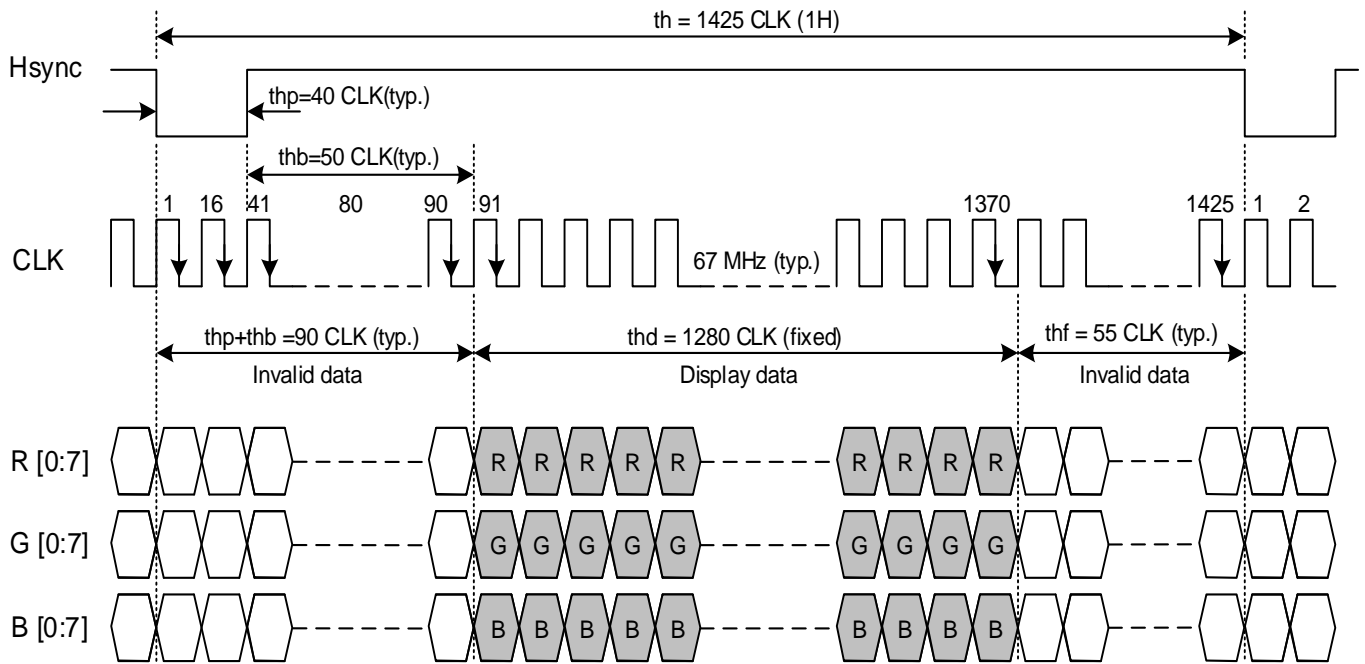

Fig. 9.1 Horizontal Timing of Synchronous Mode

Note 1: CLK's falling edge is the time to latch data and count ($thp + thb$), therefore, data sending and Hsync's falling edge should start when CLK's rise edge.

Vertical timing

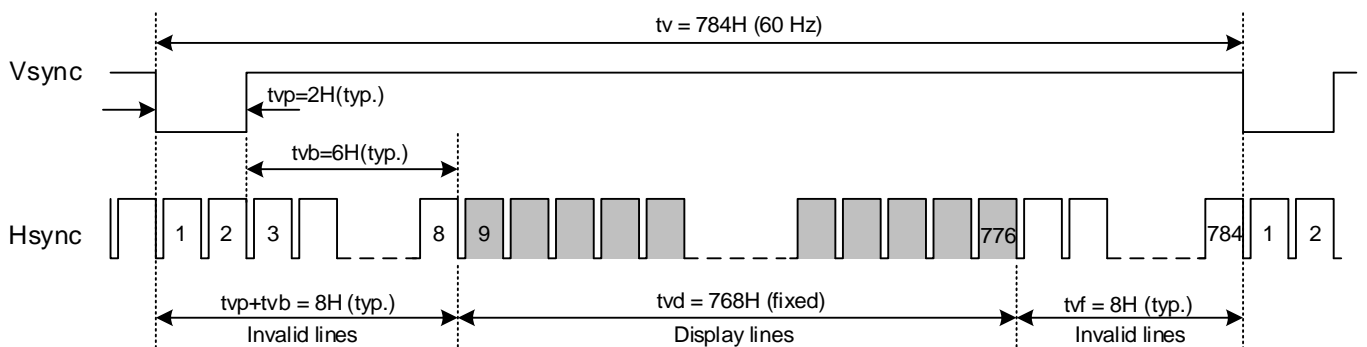

Fig. 9.2 Vertical Timing of Synchronous Mode

Note 2: Vsync's falling edge needs to start with Hsync's falling edge simultaneously to count ($tv_p + tv_b$).

9.4 TIMING TABLE

The column of timing sets including minimum, typical, and maximum as below are based on the best optical performance, frame frequency (f_{Frame}) = 60 Hz to define.

(1) Vertical timing

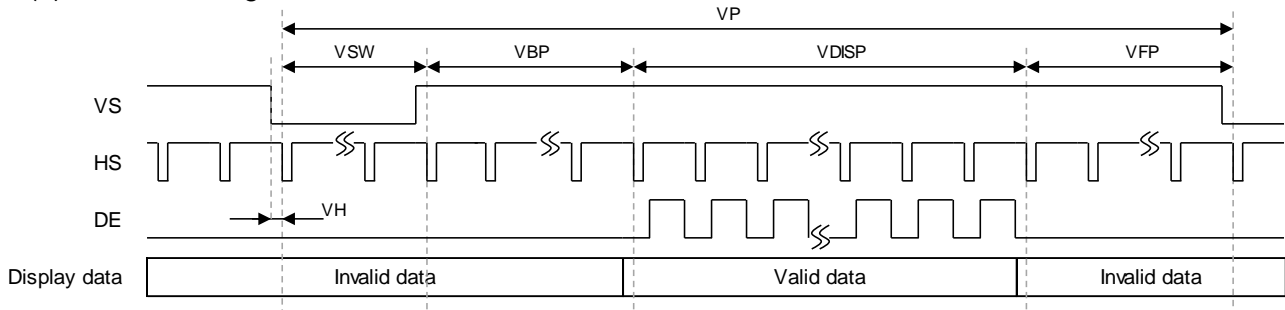

Parameter	Symbol	Min.	Typ.	Max.	Unit	Remarks
Vertical cycle	VP	784	784	784	Line	
Vertical Low pulse width	VSW	2	2	8	Line	
Vertical back porch	VBP	4	6	10	Line	
Vertical front porch	VFP	4	8	10	Line	
Vertical active area	VDISP	768	768	768	Line	
Vertical data start position	VSW+VBP	6	8	12	Line	
Vertical total porch	VSW+VBP+VFP	16	16	16	Line	
Frame rate	VRR	58.2	60.0	61.8	Hz	

(2) Horizontal timing

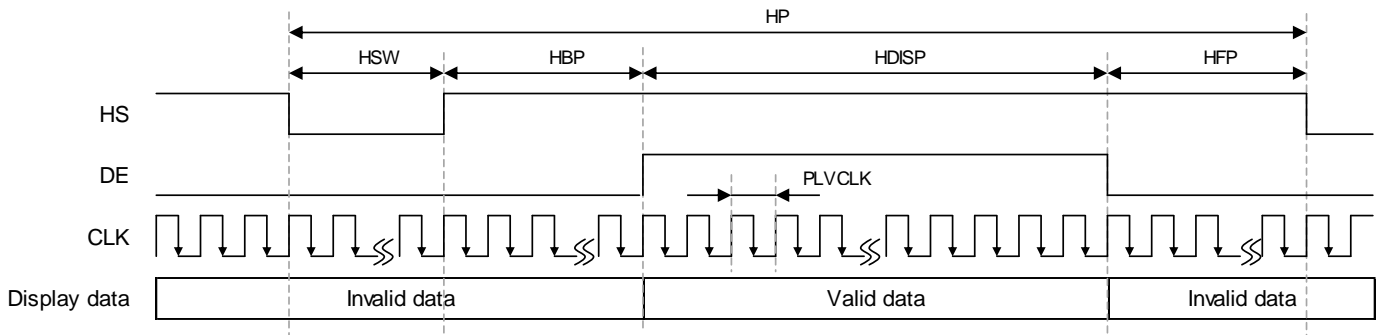

Parameter	Symbol	Min.	Typ.	Max.	Unit	Remarks
HS cycle	HP	1425	1425	1425	CLK	
HS low pulse width	HSW	20	40	85	CLK	
Horizontal back porch	HBP	20	50	85	CLK	
Horizontal front porch	HFP	40	55	105	CLK	
Horizontal active area	HDISP	1280	1280	1280	CLK	
Horizontal data start position	HSW+HBP	40	90	105	CLK	
Horizontal total porch	HSW+HBP+HFP	145	145	145	CLK	
Pixel clock frequency	fLVCLK	65.0	67.0	69.0	MHz	
	PLVCLK	14.5	14.9	15.4	ns	

9.5 DISPLAY MODE CONTROL

Scan direction is available to be switched as below by setting CN7's UD/ LR pin.

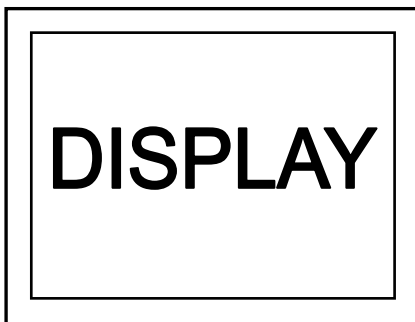

UD/LR : High



UD/LR : Low

9.6 LVDS RECEIVER TIMING

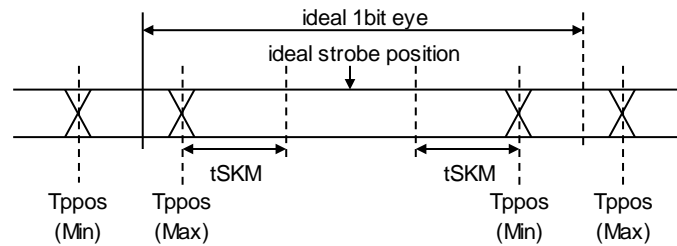
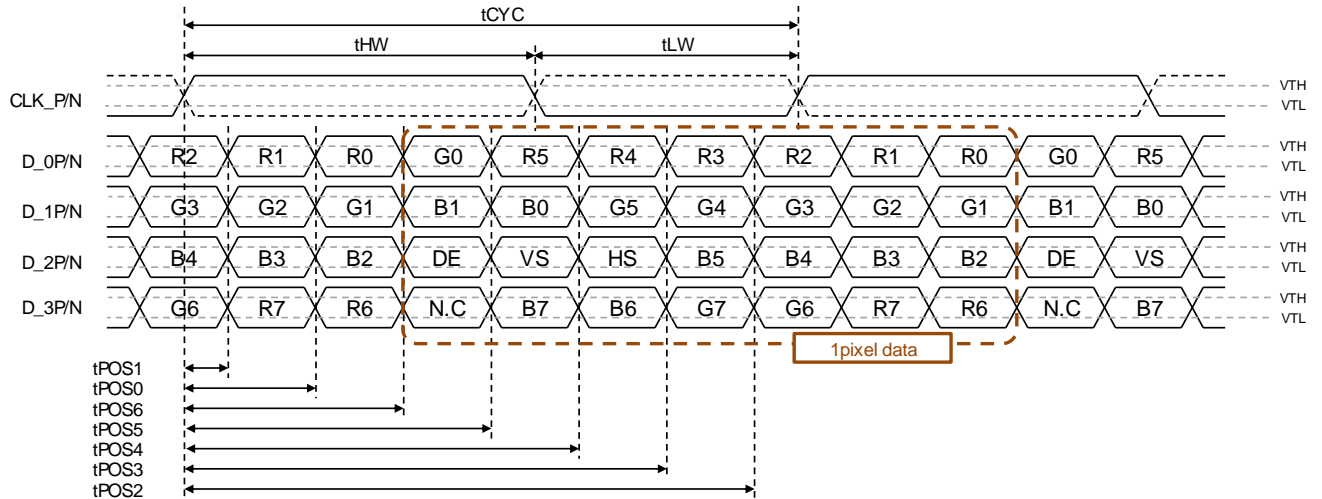

Signal	Symbol	Parameter	Min.	Typ.	Max.	Unit
CLK_P/N	tCYC	clock cycle time	14.5	14.9	15.4	ns
	tHW	clock "H" pulse width	0.4 x tCYC	0.5 x tCYC	0.6 x tCYC	ns
	tLW	clock "L" pulse width	0.4 x tCYC	0.5 x tCYC	0.6 x tCYC	ns
D[3:0]P/N,	tPOS1	tPOS1 position	- tSKM	0	+ tSKM	ns
	tPOS0	tPOS0 position	(1/7)x tCYC - tSKM	(1/7)x tCYC	(1/7)x tCYC + tSKM	ns
	tPOS6	tPOS6 position	(2/7)x tCYC - tSKM	(2/7)x tCYC	(2/7)x tCYC + tSKM	ns
	tPOS5	tPOS5 position	(3/7)x tCYC - tSKM	(3/7)x tCYC	(3/7)x tCYC + tSKM	ns
	tPOS4	tPOS4 position	(4/7)x tCYC - tSKM	(4/7)x tCYC	(4/7)x tCYC + tSKM	ns
	tPOS3	tPOS3 position	(5/7)x tCYC - tSKM	(5/7)x tCYC	(5/7)x tCYC + tSKM	ns
	tPOS2	tPOS2 position	(6/7)x tCYC - tSKM	(6/7)x tCYC	(6/7)x tCYC + tSKM	ns
	tSKM	Skew margin	-	-	(300)	ps

9.7 POWER SEQUENCE

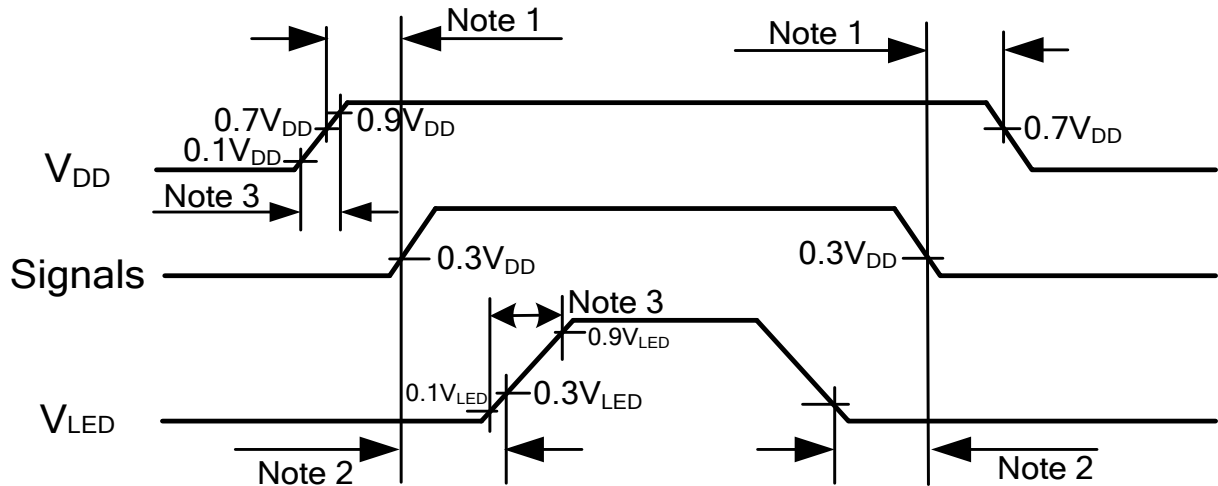

Note 1: In order to avoid any damages, V_{DD} has to be applied before all other signals. The opposite is true for power off where V_{DD} has to be remained on until all other signals have been switch off. The recommended time period is 1 second.

Note 2: In order to avoid showing uncompleted patterns in transient state. It is recommended that switching the backlight on is delayed for 1 second after the signals have been applied. The opposite is true for power off where the backlight has to be switched off 1 second before the signals are removed.

Note 3: In order to avoid high Inrush current, V_{DD} rising time need to set more than 0.5ms.

9.8 DATA INPUT for DISPLAY COLOR

Input color		Red Data								Green Data								Blue Data													
		R7	R6	R5	R4	R3	R2	R1	R0	G7	G6	G5	G4	G3	G2	G1	G0	B7	B6	B5	B4	B3	B2	B1	B0						
		MSB								LSB								MSB								LSB					
Basic Color	Black	0	0	0	0	0	0	0	0	0	0	0	0	0	0	0	0	0	0	0	0	0	0	0							
	Red(255)	1	1	1	1	1	1	1	1	0	0	0	0	0	0	0	0	0	0	0	0	0	0	0							
	Green(255)	0	0	0	0	0	0	0	0	1	1	1	1	1	1	1	1	0	0	0	0	0	0	0							
	Blue(255)	0	0	0	0	0	0	0	0	0	0	0	0	0	0	0	0	1	1	1	1	1	1	1							
	Cyan	0	0	0	0	0	0	0	0	1	1	1	1	1	1	1	1	1	1	1	1	1	1	1							
	Magenta	1	1	1	1	1	1	1	1	0	0	0	0	0	0	0	0	1	1	1	1	1	1	1							
	Yellow	1	1	1	1	1	1	1	1	1	1	1	1	1	1	1	1	0	0	0	0	0	0	0							
	White	1	1	1	1	1	1	1	1	1	1	1	1	1	1	1	1	1	1	1	1	1	1	1							
Red	Black	0	0	0	0	0	0	0	0	0	0	0	0	0	0	0	0	0	0	0	0	0	0								
	Red(1)	0	0	0	0	0	0	0	1	0	0	0	0	0	0	0	0	0	0	0	0	0	0								
	Red(2)	0	0	0	0	0	0	1	0	0	0	0	0	0	0	0	0	0	0	0	0	0	0								
	:	:	:	:	:	:	:	:	:	:	:	:	:	:	:	:	:	:	:	:	:	:	:								
	Red(253)	1	1	1	1	1	1	0	1	0	0	0	0	0	0	0	0	0	0	0	0	0	0								
	Red(254)	1	1	1	1	1	1	1	0	0	0	0	0	0	0	0	0	0	0	0	0	0	0								
	Red(255)	1	1	1	1	1	1	1	1	0	0	0	0	0	0	0	0	0	0	0	0	0	0								
Green	Black	0	0	0	0	0	0	0	0	0	0	0	0	0	0	0	0	0	0	0	0	0	0								
	Green(1)	0	0	0	0	0	0	0	0	0	0	0	0	0	0	1	0	0	0	0	0	0	0								
	Green(2)	0	0	0	0	0	0	0	0	0	0	0	0	0	1	0	0	0	0	0	0	0	0								
	:	:	:	:	:	:	:	:	:	:	:	:	:	:	:	:	:	:	:	:	:	:	:								
	Green(253)	0	0	0	0	0	0	0	0	1	1	1	1	1	1	0	1	0	0	0	0	0	0								
	Green(254)	0	0	0	0	0	0	0	0	1	1	1	1	1	1	1	0	0	0	0	0	0	0								
	Green(255)	0	0	0	0	0	0	0	0	1	1	1	1	1	1	1	1	0	0	0	0	0	0								
Blue	Black	0	0	0	0	0	0	0	0	0	0	0	0	0	0	0	0	0	0	0	0	0	0								
	Blue(1)	0	0	0	0	0	0	0	0	0	0	0	0	0	0	0	0	0	0	0	0	0	1								
	Blue(2)	0	0	0	0	0	0	0	0	0	0	0	0	0	0	0	0	0	0	0	0	1	0								
	:	:	:	:	:	:	:	:	:	:	:	:	:	:	:	:	:	:	:	:	:	:	:								
	Blue(253)	0	0	0	0	0	0	0	0	0	0	0	0	0	0	0	1	1	1	1	1	1	0								
	Blue(254)	0	0	0	0	0	0	0	0	0	0	0	0	0	0	0	1	1	1	1	1	1	0								
	Blue(255)	0	0	0	0	0	0	0	0	0	0	0	0	0	0	0	1	1	1	1	1	1	1								

Note 1: Definition of gray scale : Color(n) Number in parenthesis indicates gray scale level. Larger number corresponds to brighter level.

Note 2: Data Signal : 1 : High, 0 : Low

10. OUTLINE DIMENSIONS

10.1 FRONT VIEW

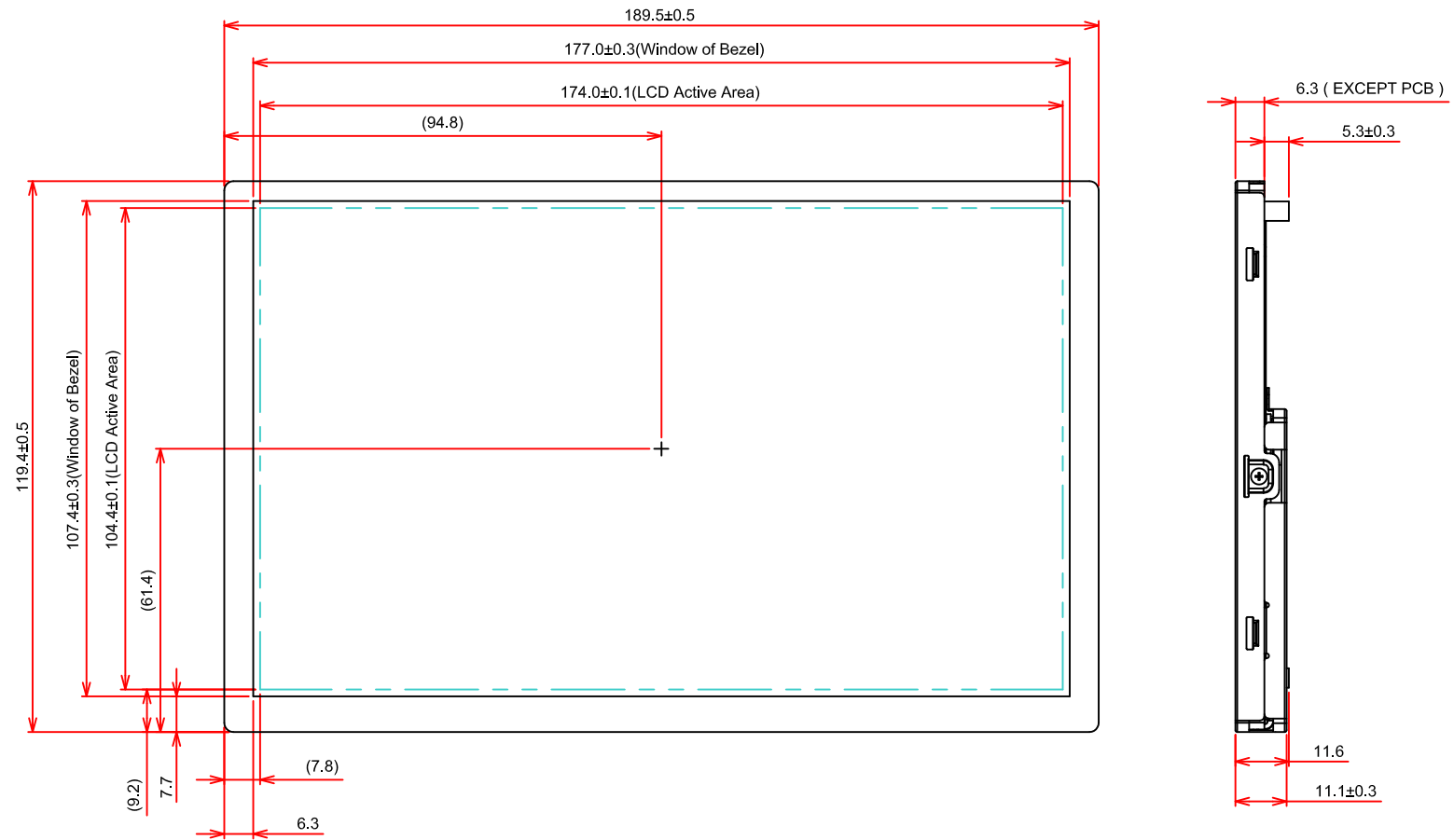

General Tolerance: ± 0.5 mm
 Scale : NTS
 Unit : mm

10.2 REAR VIEW

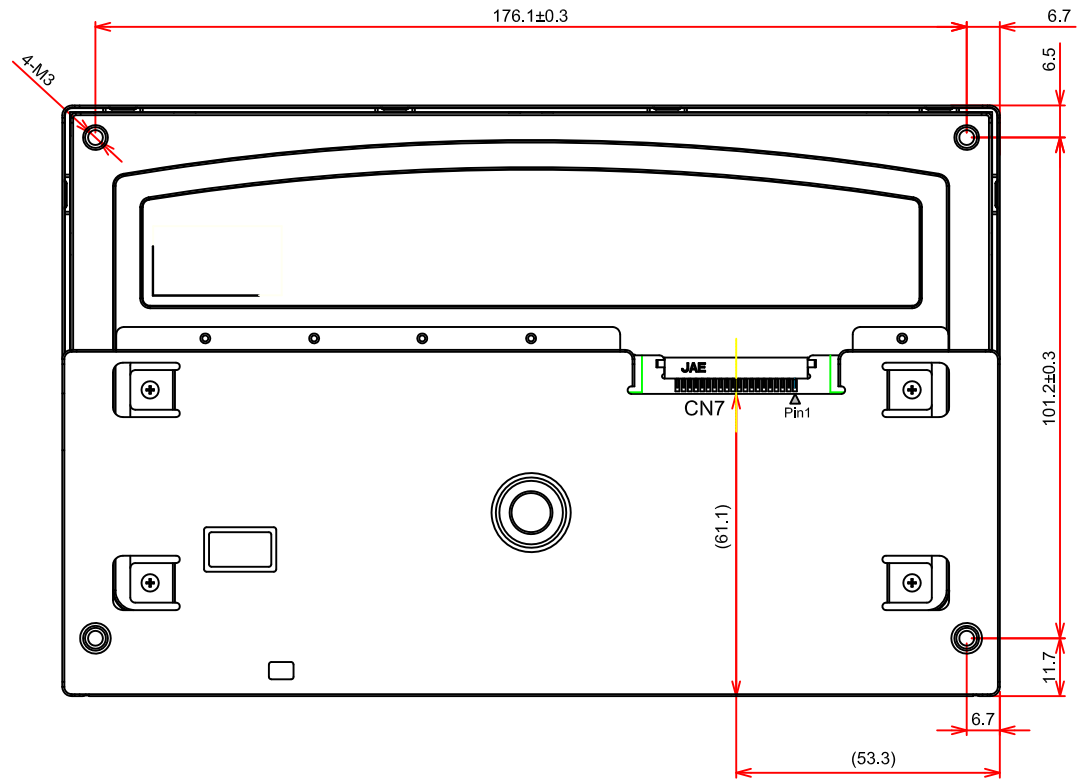

General Tolerance: ± 0.5 mm
 Scale : NTS
 Unit : mm

11. APPEARANCE STANDARD

The appearance inspection is performed in a room around 500~1000 lx based on the conditions as below:

- The distance between inspector's eyes and display is 30 cm.
- The viewing zone is defined with angle θ shown in Fig. 11.1 The inspection should be performed within 45° when display is shut down. The inspection should be performed within 5° when display is power on.

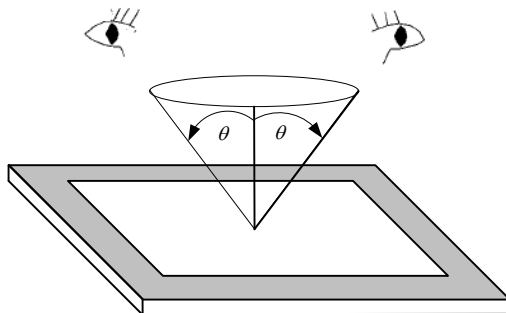

Fig. 11.1

11.1 THE DEFINITION OF LCD ZONE

LCD panel is divided into 3 areas as shown in Fig.11.2 for appearance specification in next section. A zone is the LCD active area (dot area); B zone is the area between A zone and metal frame.

In terms of housing design, B zone is the recommended window area customers' housing should be located in.

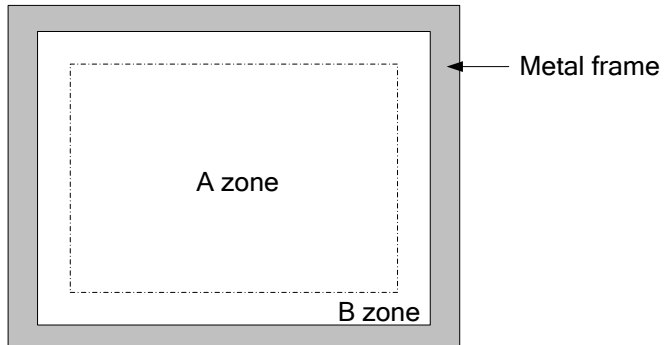

Fig. 11.2

11.2 LCD APPEARANCE SPECIFICATION

The specification as below is defined as the amount of unexpected phenomenon or material in different zones of LCD panel. The definitions of length, width and average diameter using in the table are shown in Fig. 11.3 and Fig. 11.4.

Item	Criteria				Applied zone
	Length (mm)	Width (mm)	Maximum number	Minimum space	
Scratches	Ignored	$W \leq 0.02$	Ignored	-	A, B
	$L \leq 40$	$0.02 < W \leq 0.05$	10	-	
	-	$0.05 < W$	Not allowed	-	
	Serious one is not allowed				
Dent	Serious one is not allowed				A
Wrinkles in polarizer	Serious one is not allowed				A
Bubbles on polarizer	Average diameter (mm)		Maximum number		A
	$D \leq 0.3$		Ignored		
	$0.3 < D \leq 0.5$		12		
	$0.5 < D$		Not allowed		
1) Stains 2) Foreign Materials 3) Dark Spot	Filamentous (Line shape)				A, B
	Length (mm)	Width (mm)	Maximum number		
	$L \leq 2.0$	$W \leq 0.03$	Ignored		
	$L \leq 3.0$	$0.03 < W \leq 0.05$	10		
	$L \leq 2.5$	$0.05 < W \leq 0.1$	1		
	Round (Dot shape)				A, B
	Average diameter (mm)		Maximum number	Minimum Space	
	$D \leq 0.2$		Ignored	-	
	$0.2 < D \leq 0.3$		10	10 mm	
	$0.3 < D \leq 0.4$		5	30 mm	
	$0.4 < D$		Not allowed	-	
	In total		Filamentous + Round=10		
	Those wiped out easily are acceptable				
	Dot-Defect (Note 1)			Type	Maximum number
Bright dot-defect		1 dot	0		
Dark dot-defect		1 dot	5		
		2 adjacent dot			
		3 adjacent dot or above	Not allowed		
In total		5			
In total		5			
Mura	Invisible through 2% ND filter				A (Note 2)

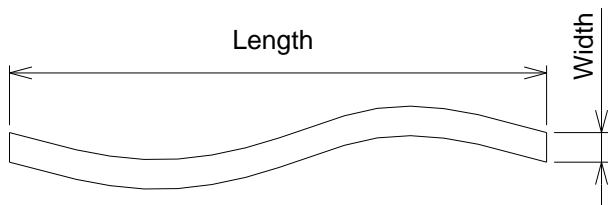

Fig 11.3

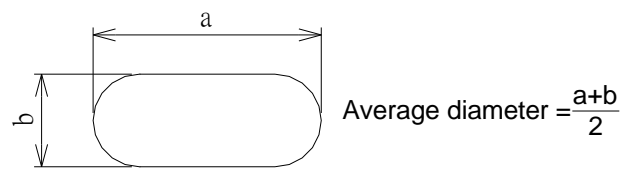

Fig 11.4

Note 1: The definitions of dot defect are as below:

- For bright dot-defect, showing black pattern, visible with 5% ND filter is defined.
- For dark dot-defect, showing white pattern, defect size over 1/2 dot area is defined.
- The definition of 1-dot-defect is the defect-dot, which is isolated and no adjacent defect-dot.
- The definition of adjacent dot is shown as Fig. 11.5.
- The Density of dot defect is defined in the area within diameter $\phi = 10\text{mm}$.

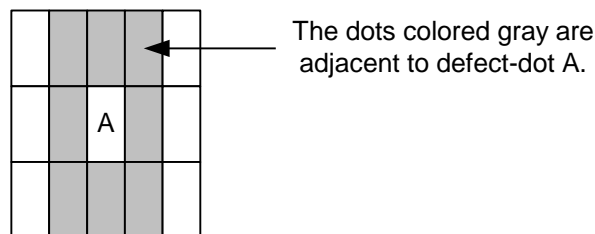
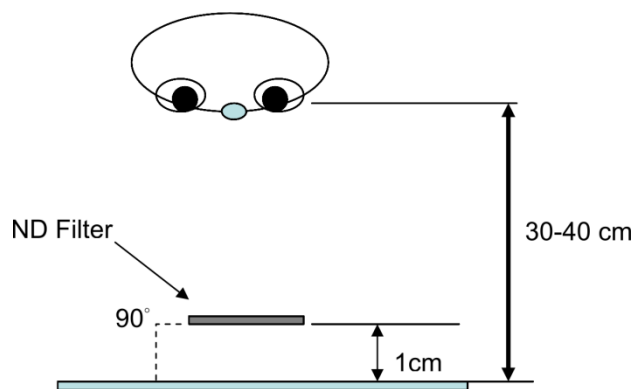

Fig. 11.5

Note 2: The inspection method with ND Filter is to hold it in front of the panel around 1 cm and inspect the panel with 35±5 cm distance for 1 second.



12. PRECAUTIONS

12.1 PRECAUTIONS of ESD

- 1) Before handling the display, please ensure your body has been connected to ground to avoid any damages by ESD. Also, do not touch display's interface directly when assembling.
- 2) Please remove the protection film very slowly before turning on the display to avoid generating ESD.

12.2 PRECAUTIONS of HANDLING

- 1) In order to keep the appearance of display in good condition, please do not rub any surfaces of the displays by sharp tools harder than 3H, especially touch panel, metal frame and polarizer.
- 2) Please do not pile the displays in order to avoid any scars leaving on the display. In order to avoid any injuries, please pay more attention for the edges of glasses and metal frame, and wear finger cots to protect yourself and the display before working on it.
- 3) Touching the display area or the terminal pins with bare hand is prohibited. This is because it will stain the display area and cause poor insulation between terminal pins, and might affect display's electrical characteristics furthermore.
- 4) Do not use any harmful chemicals such as acetone, toluene, and isopropyl alcohol to clean display's surfaces.
- 5) Please use soft cloth or absorbent cotton with ethanol to clean the display by gently wiping. Moreover, when wiping the display, please wipe it by horizontal or vertical direction instead of circling to prevent leaving scars on the display's surface, especially polarizer.
- 6) Please wipe any unknown liquids immediately such as saliva, water or dew on the display to avoid color fading or any permanently damages.
- 7) Maximum pressure to the surface of the display must be less than 1.96×10^4 Pa. If the area of adding pressure is less than 1 cm^2 , the maximum pressure must be less than 1.96N.

12.3 PRECAUTIONS OF OPERATING

- 1) Please input signals and voltages to the displays according to the values defined in the section of electrical characteristics to obtain the best performance. Any voltages over than absolute maximum rating will cause permanent damages to this display. Also, any timing of the signals out of this specification would cause unexpected performance.
- 2) When the display is operating at significant low temperature, the response time will be slower than it at 25°C . In high temperature, the color will be slightly dark and blue compared to original pattern. However, these are temperature-related phenomenon of LCD and it will not cause permanent damages to the display when used within the operating temperature.
- 3) The use of screen saver or sleep mode is recommended when static images are likely for long periods of time. This is to avoid the possibility of image sticking.
- 4) Spike noise can cause malfunction of the circuit. The recommended limitation of spike noise is no bigger than $\pm 100 \text{ mV}$.

JDI Taiwan Inc. Kaohsiung Branch	SHEET NO.	7B64PS 2712-TX20D207VM0AAA-3	PAGE	12-1/2
----------------------------------	-----------	------------------------------	------	--------

12.4 PRECAUTIONS of STORAGE

If the displays are going to be stored for years, please be aware the following notices.

- 1) Please store the displays in a dark room to avoid any damages from sunlight and other sources of UV light.
- 2) The recommended long term storage temperature is between 10 C° ~35 C° and 55%~75% humidity to avoid causing bubbles between polarizer and LCD glasses, and polarizer peeling from LCD glasses.
- 3) It would be better to keep the displays in the container, which is shipped from JDI, and do not unpack it.
- 4) Please do not stick any labels on the display surface for a long time, especially on the polarizer.

13. DESIGNATION of LOT MARK

1) The lot mark is showing in Fig.13.1. First 4 digits are used to represent production lot, T represented product of JDI Taiwan, and the last 6 digits are the serial number.

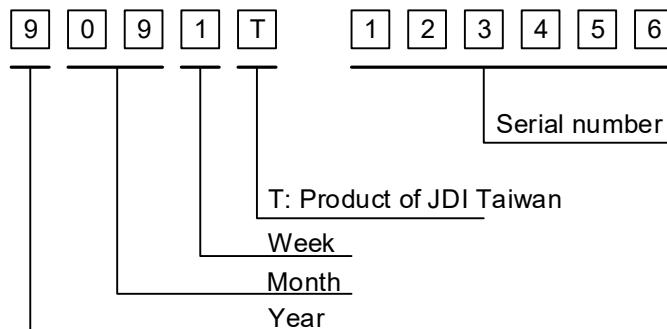

Fig. 13.1

2) The tables as below are showing what the first 4 digits of lot mark are shorted for.

Year	Lot Mark
2019	9
2020	0
2021	1
2022	2
2023	3

Month	Lot Mark	Month	Lot Mark
Jan.	01	Jul.	07
Feb.	02	Aug.	08
Mar.	03	Sep.	09
Apr.	04	Oct.	10
May	05	Nov.	11
Jun.	06	Dec.	12

Week	Lot Mark
1~7 days	1
8~14 days	2
15~21 days	3
22~28 days	4
29~31 days	5

3) Except letters I and O, revision number will be shown on lot mark and following letters A to Z.

4) The location of the lot mark is on the back of the display shown in Fig. 13.2

Label example :



Fig. 13.2